

Model RHHT-C2 Series Transport Cabinet (With Gentle Convection Heat)



Performance Features

- **Whisper Touch™** *Gentle Convection* maintains proper holding temperatures no matter the frequency of "in & out" to retrieve product
- **Whisper Touch™** surrounds products with just the right amount of heat and air to maintain that just cooked look and flavor hour after hour
- Keeps fried foods hot and moist on the inside and crispy fried on the outside
- Ideal for fried foods, bulk pans of entrees and side dishes, pies, biscuits, even boxed pizza and pre-pack meals
- Maintains safe food holding temperatures for extended holding times: allowing for advanced preparation
- Ideally suited for school foodservice, catering, and banquet applications
- Hold temperature range: 75F – 200F

Construction Features

- Self-contained power module for ease of service
- Fully insulated construction
- Type 304 welded steel body
- 12 gauge internal frame for strength
- Field Reversible Door
- Latch is magnetic/mechanical style
- Long lasting, high temperature silicone door gasket
- Four heavy duty, 6" swivel casters, two with brakes
- Lift out interior for easy cleaning
- Transport latch
- Perimeter bumper
- Side lift handles



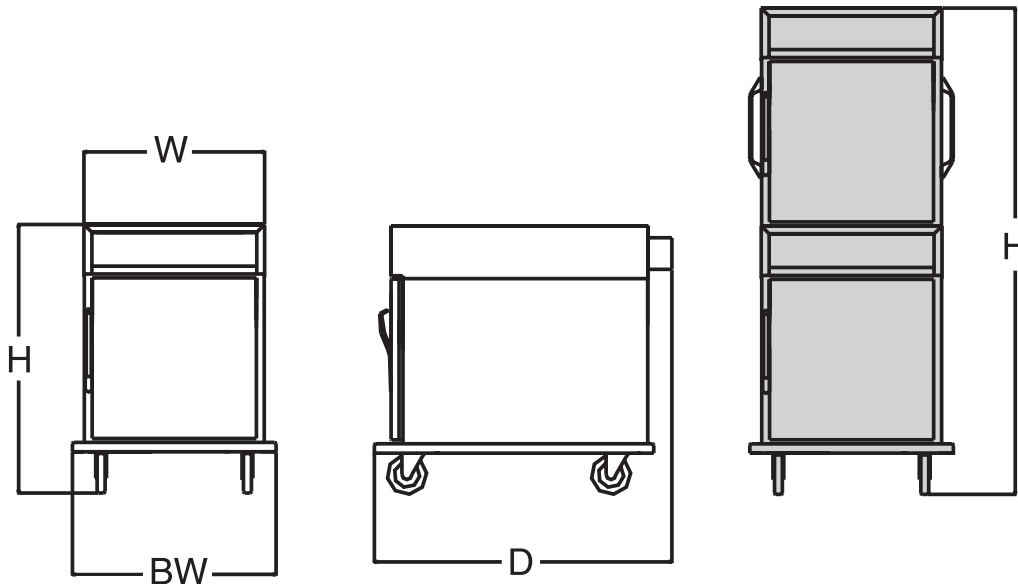

Model Number	Pan Capacity Per Holding Cabinet Pan Spacing Per Holding Cabinet C2US 6 1/4" Fixed						Height (H)	Depth (D)	Width (W)	Base Width (BW)	Shipping Wt. (lbs)	Volts	Total Watts Per Holding Compartment	Total Amps Per Holding Compartment	Hertz/Phase	Power Cord Plug (NEMA)
	18x26x1 Sheet		12x20x2 1/2 Pan		12x20x4 Pan											
	STD *	MAX	STD *	MAX	STD *	MAX										
RHHT-1000-C2US	4	4	8	8	8	8	42 3/4	35 3/8	26	29	335	120	1000	8.6	50/60 1Ø	5-15P

Bidding Specifications

Royalton Model # RHHT-___-C2US___, gentle convection holding cabinet, fully insulated, all stainless steel construction, single door with solid-state controls incorporated in the self-contained, removable power module. Digital temperature readout.

* Options

- Interiors available for:
12x20x2 1/2
12x20x4
12x20x6
18x26x1
or any combination of these pans
- Latch Magnetic/Mechanical w/Key Lock
- Consult Factory

Optional Power Module

- 2000 Watt Top=
RHHT-2000-C2US
120V 50/60 Hz 1Ø
16.6A
Nema 5-20P

