

## **Model RHHR-C2R Series Radiant Heated Holding Cabinet**



---

### **Performance Features**

---

- **Gentle Touch™** *Radiant Heat Hold* produces unsurpassed holding times
- 24 hour (or longer) holding capability for all types of meats
- Induces optimum enzyme action to naturally tenderize or “age” meats
- Delivers more flavorful, tender, and juicer meats
- Superior holding capability allows for banquet preparation well in advance of serving time
- Maintains just cooked appearance and flavor in excess of reasonable holding times
- Hold temperature range: 75F – 200F

---

### **Construction Features**

---

- Self-contained power module for ease of service
- Removable twist lock cord set
- Fully insulated construction
- Type 304 welded stainless steel body
- 12 gauge internal frame for strength
- Field reversible doors
- Latch is magnetic/mechanical style
- Long lasting, high temperature silicone door gasket
- Four heavy duty, 5” swivel casters, two with brakes
- Lift out oven interior for easy cleaning
- Radiant heat source in side walls for superior holding and serviceability



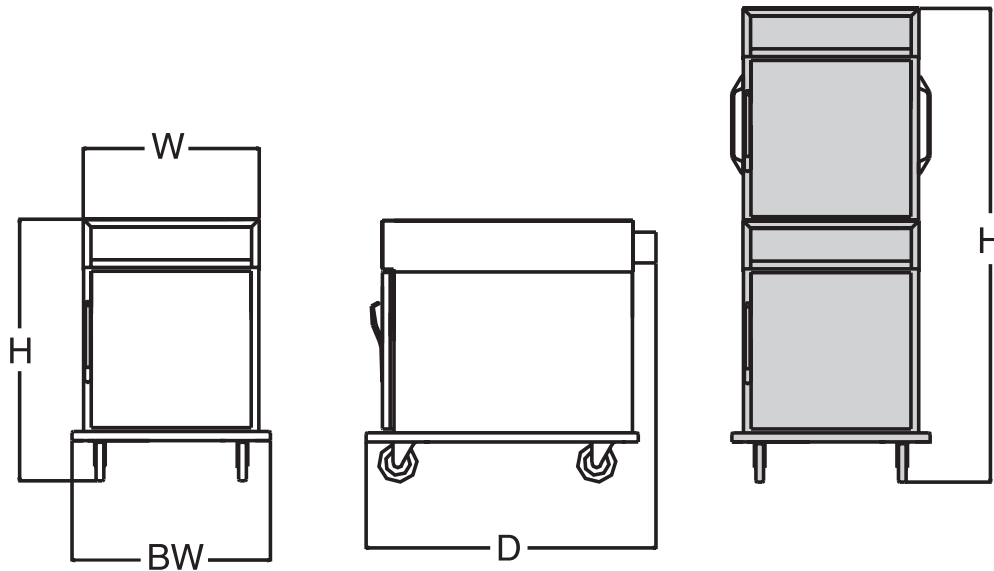

Model Number	Pan Capacity Per Holding Cabinet Pan Spacing Per Holding Cabinet C2R 3 1/4" Fixed C2USR 1 1/2" Adjustable						Height (H)	Depth (D)	Width (W)	Base Width (BW)	Shipping Wt. (lbs)	Volts	Total Watts Per Holding Compartment	Total Amps Per Holding Compartment	Hertz/Phase	Power Cord Plug (NEMA)
	18x26x1 Sheet		12x20x2 1/2 Pan		13x26x2 5/8 Basket											
	STD *	MAX	STD *	MAX	STD	MAX										
<b>RHHR-1000-C2R</b>	7	7					41 3/4	35 3/8	22 3/4	25 3/4	252	120	1000	8.6	50/60 1Ø	5-15P 
<b>RHHR-1000-C2RX •</b>	14	14									504					
<b>RHHR-1000-C2USR</b>	6	14+	12	14+			41 3/4		26	29	296					
<b>RHHR-1000-C2USRX •</b>	12	28+	24	28+							592					

X Denotes stacked unit. + Requires additional pan slides  
• Two electrical circuits required

### Bidding Specifications

Royalton Model # RHHR-1000-C2\_\_R, gentle radiant heated holding cabinet, fully insulated, all stainless steel construction with in-wall radiant heating and solid-state controls incorporated in the self-contained, power module. Digital temperature readout.

### Options

- Correctional Package
- Casters – Specials and Sizes
- Pass-Through Doors
- Tempered Glass Doors Full View
- Transport Latch
- Side Lift Handles
- Legs
- Perimeter Bumper
- Raised Wire Grid for 18x26 Pan
- Wire Shelf Interior
- Cold Pack
- Stacking Kit

• @HW 'A U[ bYh]WA YWUb]W'k #?Ym@W

\* RHHR-C2R body furnished with fixed pan slides to hold (7) 18x26 pans max.

\* RHHR-C2USR body furnished with 6 sets of universal pan slides, optional up to 14 sets.

NOTE: Double quantities for stacked units.