

## **Model RHBC-90B Series Heated Banquet Cabinet (With Gentle Convection Heat)**



### **Performance Features**

- Specially designed interior side racks and 5 wire shelves to hold up to 90 covered meals
- **Whisper Touch™ Gentle Convection** maintains proper holding temperatures no matter the frequency of "in & out" to retrieve product
- **Whisper Touch™** surrounds products with just the right amount of heat and air to maintain that just cooked look and flavor hour after hour
- Keeps fried foods hot and moist on the inside and crispy fried on the outside
- Ideal for fried foods, bulk pans of entrees and side dishes, pies, biscuits, even boxed pizza and pre-pack meals
- Maintains safe food holding temperatures for extended holding times: allowing for advanced preparation
- Ideally suited for school foodservice, catering, and banquet applications
- Hold temperature range: 75F – 200F

### **Construction Features**

- Self-contained power module for ease of service
- Fully insulated construction
- Type 304 welded body
- 12 gauge internal frame for strength
- Field reversible dutch doors
- Latch is magnetic/mechanical style
- Long lasting, high temperature silicone door gasket
- Four heavy duty, 5" swivel casters, two with brakes
- Lift out oven interior for easy cleaning
- Push/pull handles



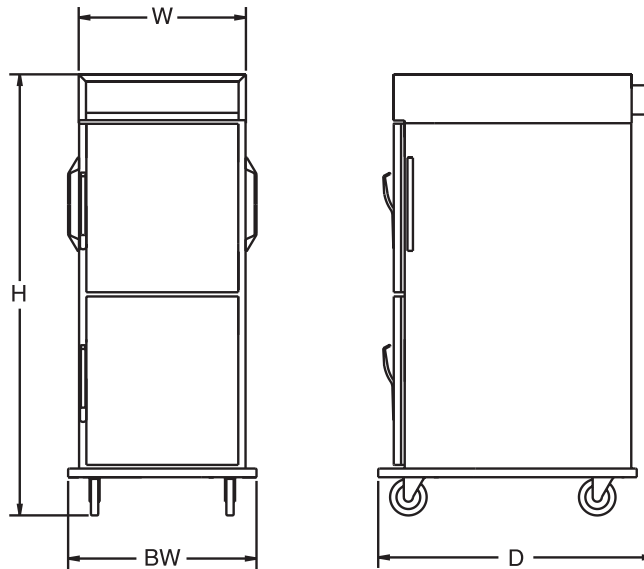

| Model Number         | Pan Capacity Per Holding Cabinet<br>Pan Spacing Per Holding Cabinet<br>C4W Top Rack 13" Fixed<br>Bottom Rack 11½" Fixed |     |              |     |               |     | Height (H) | Depth (D) | Width (W) | Base Width (BW) | Shipping Wt. (lbs) | Volts | Total Watts Per Holding Compartment | Total Amps Per Holding Compartment | Hertz/Phase | Power Cord Plug (NEMA)   |
|----------------------|---|-----|--------------|-----|---------------|-----|------------|-----------|-----------|-----------------|--------------------|-------|-------------------------------------|------------------------------------|-------------|--|
|                      | 18x26x1 Sheet   |     | 12x20x2½ Pan |     | Covered Meals |     |            |           |           |                 |                    |       |                                     |                                    |             |  |
|                      | STD *   | MAX | STD          | MAX | STD *         | MAX |            |           |           |                 |                    |       |                                     |                                    |             |  |
| <b>RHBC-2000-90B</b> | 5   | 5   |              |     | 90            | 90  | 74¾        | 37½       | 30½       | 33½             | 479                | 120   | 2000                                | 16.6                               | 50/60<br>1Ø | 5-20P<br> |

**Bidding Specifications**

Royalton Model # RHBC-2000-90B, gentle convection holding cabinet, fully insulated, all stainless steel construction with solid-state controls incorporated in the self-contained, removable power module. Digital temperature readout. Holds up to 90 covered meals on 5 wire shelves.

**Options**

- Correctional Package
- Casters – Specials and Sizes
- Pass-Through Doors
- Tempered Glass Doors Full View
- Transport Latch
- Legs
- Perimeter Bumper
- Cold Pack
- Latch Magnetic/Mechanical w/Key Lock

\* RHBC-90B body furnished with fixed pan slides to hold (5) 18x26 pans max, or (90) covered meals using 10" plates and 3" high covered domes.