

Model RHHC-C2 Series Heated Holding Cabinet (With Gentle Convection Heat)



Performance Features

- **Whisper Touch™** *Gentle Convection* maintains proper holding temperatures no matter the frequency of "in & out" to retrieve product
- **Whisper Touch™** surrounds products with just the right amount of heat and air to maintain that just cooked look and flavor hour after hour
- Keeps fried foods hot and moist on the inside and crispy fried on the outside
- Ideal for fried foods, bulk pans of entrees and side dishes, pies, biscuits, even boxed pizza and pre-pack meals
- Maintains safe food holding temperatures for extended holding times: allowing for advanced preparation
- Ideally suited for school foodservice, catering, and banquet applications
- Hold temperature range: 75F – 200F

Construction Features

- Self-contained power module for ease of service
- Fully insulated construction
- Type 304 welded stainless steel body
- 12 gauge internal frame for strength
- Field reversible doors
- Latch is magnetic/mechanical style
- Long lasting, high temperature silicone door gasket
- Four heavy duty, 5" swivel casters, two with brakes
- Lift out oven interior for easy cleaning



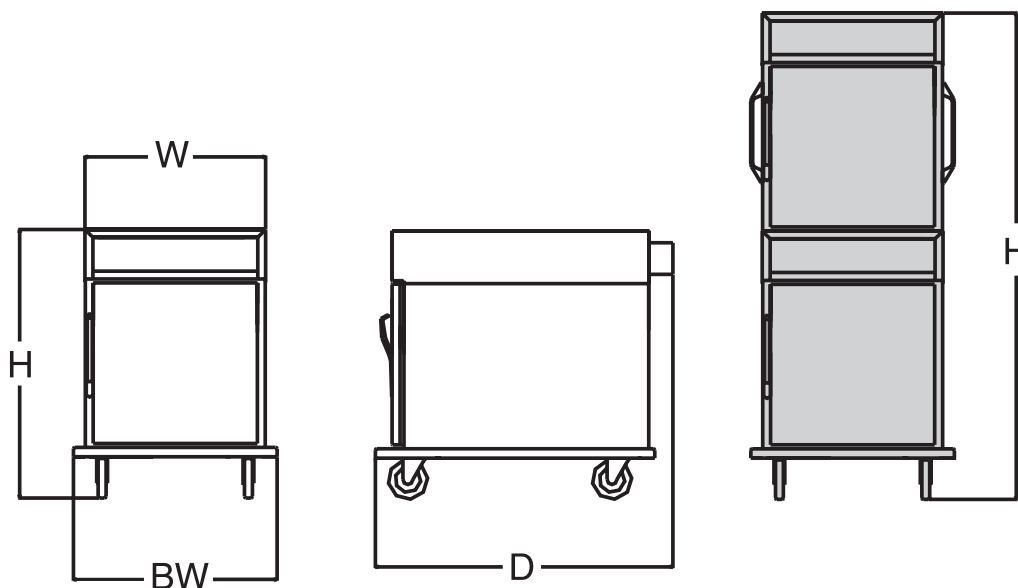

Model Number	Pan Capacity Per Holding Cabinet Pan Spacing Per Holding Cabinet C2 3 1/4" Fixed C2US 1 1/2" Adjustable C2W 3 1/2" Fixed						Height (H)	Depth (D)	Width (W)	Base Width (BW)	Shipping Wt. (lbs)	Volts	Total Watts Per Holding Compartment	Total Amps Per Holding Compartment	Hertz/Phase	Power Cord Plug (NEMA)
	18x26x1 Sheet		12x20x2 Pan		13x26x2 5/8 Basket											
	STD *	MAX	STD *	MAX	STD *	MAX										
RHHC-1000-C2	8	8					41 3/4	35 3/8	22 3/4	25 3/4	280	120	1000	8.6	50/60 1Ø	5-15P 
RHHC-1000-C2X •	16	16														
RHHC-1000-C2US	4	15+	12	16+			41 3/4		26	29	325					
RHHC-1000-C2USX •	12	30+	24	32+												
RHHC-1000-C2W	8	8			16	16	41 3/4				298					
RHHC-1000-C2WX •	16	16			32	32	77		30 1/2	33 1/2						

X Denotes stacked unit. + Requires additional pan slides

• Two electrical circuits required

Bidding Specifications

Royalton Model # RHHC-___-C2___, gentle convection holding cabinet, fully insulated, all stainless steel construction with solid-state controls incorporated in the self-contained, removable power module. Digital temperature readout.

Options

- Correctional Package
- Casters – Specials and Sizes
- Pass-Through Doors
- Tempered Glass Doors Full View
- Transport Latch
- Side Lift Handles
- Legs
- Shelving – Wire Rack
- Perimeter Bumper
- Cold Pack
- Stacking Kit
- Raised Wire Grid for 18x26 Pan
- Wire Shelf Interior
- Latch Magnetic/Mechanical w/Key Lock

* RHHC-C2 body furnished with fixed pan slides to hold (8) 18x26 pans max.

* RHHC-C2US body furnished with 6 sets of adjustable universal pan slides, optional up to 15 sets.

* RHHC-C2W body furnished with fixed pan slides to hold (8) 18x26 pans or (16) 13x26x2 5/8 baskets, max.

NOTE: Double quantities for stacked units.