

Model RHHC-C1 Series Heated Holding Cabinet (With Gentle Convection Heat)



Performance Features

- **Whisper Touch™ Gentle Convection** maintains proper holding temperatures no matter the frequency of "in & out" to retrieve product
- **Whisper Touch™** surrounds products with just the right amount of heat and air to maintain that just cooked look and flavor hour after hour
- Keeps fried foods hot and moist on the inside and crispy fried on the outside
- Ideal for fried foods, bulk pans of entrees and side dishes, pies, biscuits, even boxed pizza and pre-pack meals
- Maintains safe food holding temperatures for extended holding times: allowing for advanced preparation
- Ideally suited for school foodservice, catering, and banquet applications
- Hold temperature range: 75F – 200F

Construction Features

- Self-contained power module for ease of service
- Fully insulated construction
- Type 304 welded stainless steel body
- 12 gauge internal frame for strength
- Field reversible doors
- Latch is magnetic/mechanical style
- Long lasting, high temperature silicone door gasket
- Four heavy duty, 5" swivel casters, two with brakes
- Lift out oven interior for easy cleaning



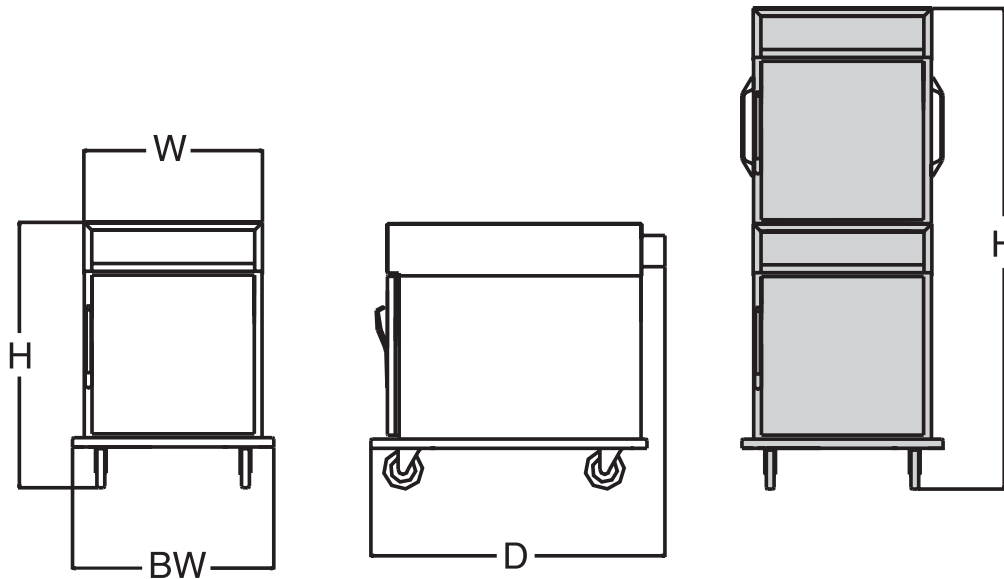

Model Number	Pan Capacity Per Holding Cabinet Pan Spacing Per Holding Cabinet C1 3 ³ / ₈ " Fixed C1US 1 ¹ / ₂ " Adjustable C1W 3 ¹ / ₂ " Fixed						Height (H)	Depth (D)	Width (W)	Base Width (BW)	Shipping Wt. (lbs)	Volts	Total Watts Per Holding Compartment	Total Amps Per Holding Compartment	Hertz/Phase	Power Cord Plug (NEMA)
	18x26x1 Sheet		12x20x2 Pan		13x26x2 ⁵ / ₈ Basket											
	STD *	MAX	STD *	MAX	STD *	MAX										
RHHC-1000-C1	5	5					34	35 ³ / ₈	22 ³ / ₄	25 ³ / ₄	218	120	1000	8.6	50/60 1Ø	5-15P 
RHHC-1000-C1X •	10	10					436									
RHHC-1000-C1US	4	11+	8	12+			34		26	29	237					
RHHC-1000-C1USX •	8	22+	16	24+			474									
RHHC-1000-C1W	5	5			10	10	34		30 ¹ / ₂	33 ¹ / ₂	237					
RHHC-1000-C1WX •	10	10			20	20	61 ⁵ / ₈				454					

X Denotes stacked unit. + Requires additional pan slides
• Two electrical circuits required

Bidding Specifications

Royalton Model # RHHC-___-C1___, gentle convection holding cabinet, fully insulated, all stainless steel construction with solid-state controls incorporated in the self-contained, removable power module. Digital temperature readout.

Options

- Correctional Package
- Casters – Specials and Sizes
- Pass-Through Doors
- Tempered Glass Doors Full View
- Transport Latch
- Side Lift Handles
- Legs
- Shelving – Wire Rack
- Perimeter Bumper
- Cold Pack
- Stacking Kit
- Raised Wire Grid for 18x26 Pan
- Wire Shelf Interior
- Latch Magnetic/Mechanical w/Key Lock

* RHHC-C1 body furnished with fixed pan slides to hold (5) 18x26 pans max.

* RHHC-C1US body furnished with 4 sets of adjustable universal pan slides, optional up to 11 sets.

* RHHC-C1W body furnished with fixed pan slides to hold (5) 18x26 pans or (10) 13x26x2 5/8 baskets, max.

NOTE: Double quantities for stacked units.